

# GC6-2422

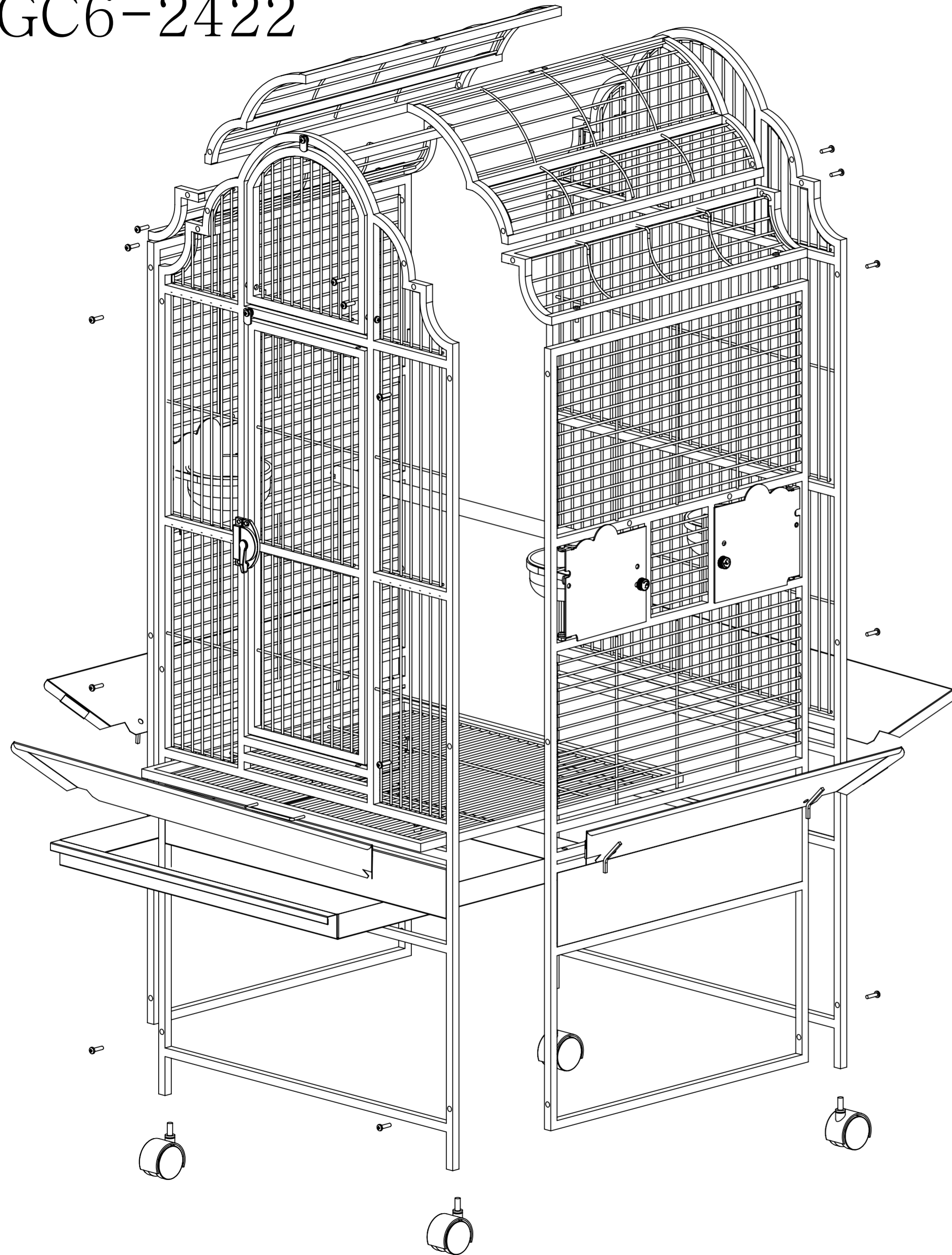

## Box List

Item No: GC6-2422				
Box 1/2		Worker	Q C	ganger
Part name	Quantity			
Front wire(前网)	1pcs			
Back wire(后网)	1pcs			
Left wire(左网)	1pcs			
Right wire(右网)	1pcs			
Seed guards(裙边)	4pcs			
Assembly Instructions(包装图)	1pcs			
Upper perch(上棍)	1pcs			
Bottom perch(下棍)	1pcs			
Box 2/2		Worker	Q C	ganger
Grill(密网)	1pcs			
Upper top wire (上盖网)	2pcs			
Low top wire (下盖网)	2pcs			
Tray(铁盆)	1pcs			
Wheels(1.5寸8厘脚轮)	4pcs			
Feeders(5寸杯)	3pcs			
Holder(5寸合圈)	3pcs			
Screw bag(螺丝包)	1pcs			

1. Screw 2 x wheels onto bottom of front wire & back wire;
2. Assembly front 、back、 left、 right wire together with screws to form a body;
3. Assembly corner wire on top of left and right wire with screws;
4. Assembly top wire on the top of the body to get a cage;
5. Slide grill and tray into bottom of the cage;
6. Insert seed guard into bottom of the cage;
7. Put the feeder dish into the dish door and the perches into the cage.
8. Open the top wire and put perch as you will !