

B-2620

Box List

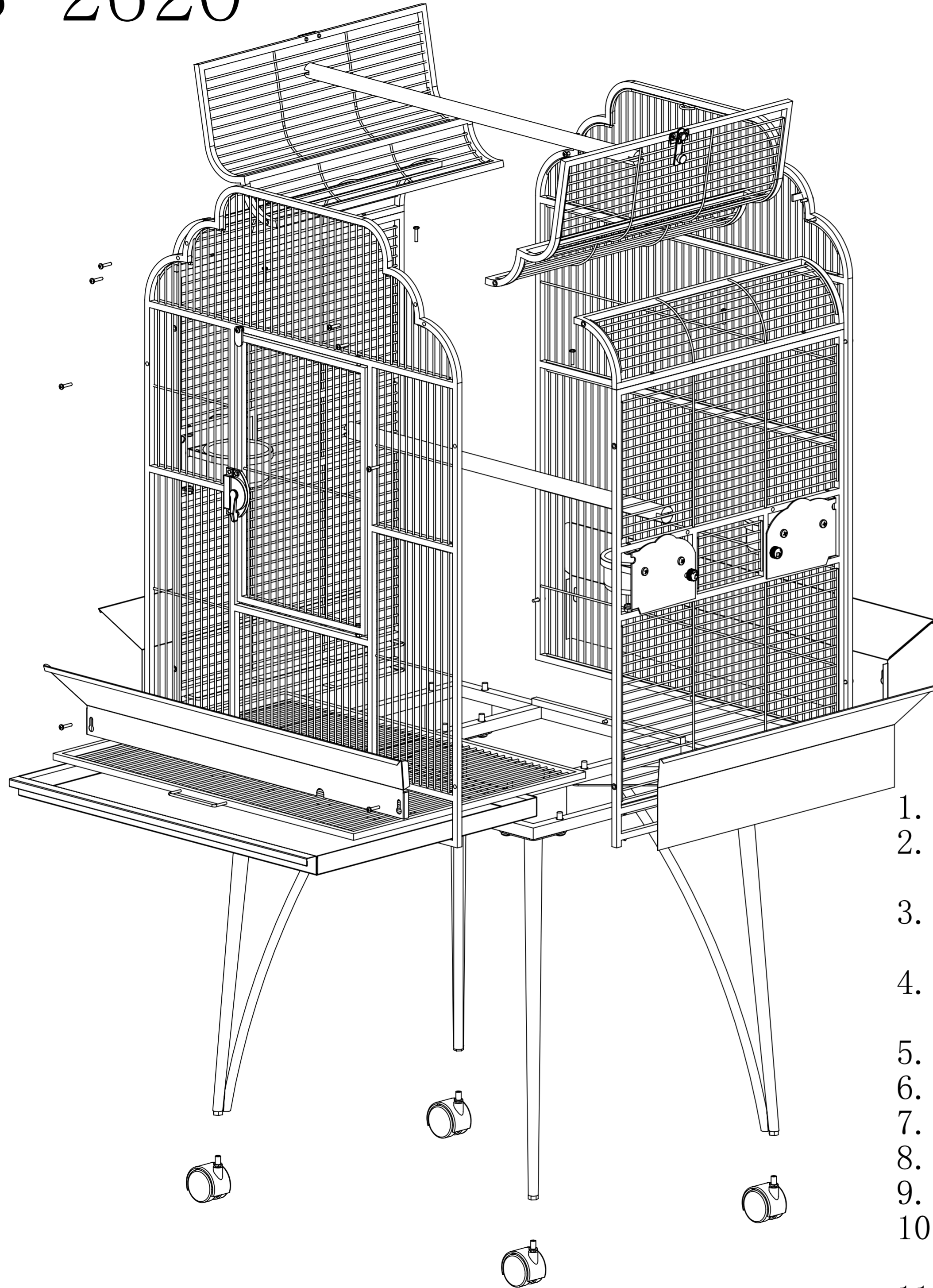

Item No: B-2620		Worker	Q C	ganger
Box				
Part name	Quantity			
Front wire(前网)	1pcs			
Back wire(后网)	1pcs			
Left wire(左网)	1pcs			
Right wire(右网)	1pcs			
Seed guards(裙边)	4pcs			
Legs(脚)	4pcs			
Frame(脚框)	1pcs			
Assembly Instructions(包装图)	1pcs			
Upper perch(上棍)	1pcs			
Bottom perch(下棍)	1pcs			
Grill(密网)	1pcs			
Upper top wire(上盖网)	2pcs			
Low top wire(下盖网)	2pcs			
Tray(铁盆)	1pcs			
Wheels(1.5寸8厘脚轮)	4pcs			
Feeders(4寸杯)	3pcs			
Holder(4寸合圈)	3pcs			
Screw bag(螺丝包)	1pcs			

1. Screw 4 x wheels onto bottom of the 4 x legs ;
2. Attach 4 x legs and leg frame together with screws to form a stand;
3. Assembly front 、 back、 left、 right wire together with screws to form a body;
4. Assembly corner wire on top of left and right wire with screws;
5. Assembly top wire on the top of the body ;
6. Put the cage onto the stand;
7. Contact cage and stand tightly with screws ;
8. Slide grate and base into bottom of the cage;
9. Insert seed guard into bottom of the cage;
10. Put the feeder dish into the dish door and the perches into the cage.
11. Open the top wire and put perch as you will !